



Pall Aerospace



Pall Aeropower Corporation

Portable Fluid Purifier



Fluid Purification Solution for
Hydraulic Oils, Lubricants, Coolant Fluids

The Portable Fluid Purifier



Removal of water, gases, solvents and particulate from oils such as:

- hydraulic fluids
- lubrication fluids
- coolants, and
- synthetic fluids

Prevents pollution, increases equipment reliability and performance while reducing costly maintenance.

Benefits of the Portable Fluid Purifier

Extend Fluid Service Life

- Experience significant reduction in oil change out due to contamination; extend oil change intervals

Reduce Fluid Disposal Costs and Environmental Risk

- Decrease the need to store, maintain and transport contaminated fluids for disposal

Prevent Pollution / Recycle

- Minimize fluid waste disposal and extend fluid service life through reuse / recycle

Improve Hydraulic System Response

- Encounter fewer costly operational delays
- Benefit from increased system reliability
- Experience improved system response with de-aerated fluid

Improve On-Line Performance

- Reduce system downtime resulting from fluid-related service interruptions

Reduce System Wear

- Increase MTBUR
- Maintain a smaller spare parts inventory

Return on Investment

Low operating and maintenance costs make the Pall Purifier cost effective and minimize the investment payback period

The Optimal Fluid Purification System

The PAC portable fluid purifier is small, light-weight, energy efficient and highly mobile. The system is designed to maximize ease of use, economy, reliability, and maintainability. It will operate unattended for extended periods of time with built-in safety features including: diagnostics for fault detection with automatic shutdown, fault signal lights, and smart controls to signal the need for filter changeout.

Pall's spinning disk purifier has been specially developed to minimize degradation of the working properties of the fluid being purified. The system employs mass transfer technologies which are the most gentle to the fluids.

PAC's portable fluid purifier does not use desiccants, molecular sieves, high vacuum, or added heat typical of flash distillation units. It has minimal impact on the working properties of fluid.

Alternate Processes and Potential Problems:

PURIFICATION PROCESS	POTENTIAL PROBLEMS
Desiccant or Molecular Sieve	Strips out fluid additives. Potential for desiccant and molecular sieve material to be released into the fluid.
High Vacuum	Strips the fluid of light ends and volatile additives. Can result in fluid viscosity increase.
Added Heat	Causes fluid oxidation, coking or charring. Strips the fluid of light ends and volatile additives. Can result in fluid viscosity increase.

Pall Aeropower Corporation (PAC) introduced its fluid purifier in 1965 to remove sea water contamination from U.S. Navy submarine hydraulic systems. Today, PAC purifiers are used to prevent pollution, extend fluid service life, recycle fluids, and maintain optimum fluid cleanliness levels in ships, aircraft, military vehicles, ground support equipment, fluid test stands, and many other applications.

The PAC portable fluid purifier is specially configured to extend the fluid service life of hydraulic fluids, lube fluids, polyalphaolefin (PAO) based fluids, coolants, phosphate ester fluids, poly-ol ester fluids, and many others.

System Operation

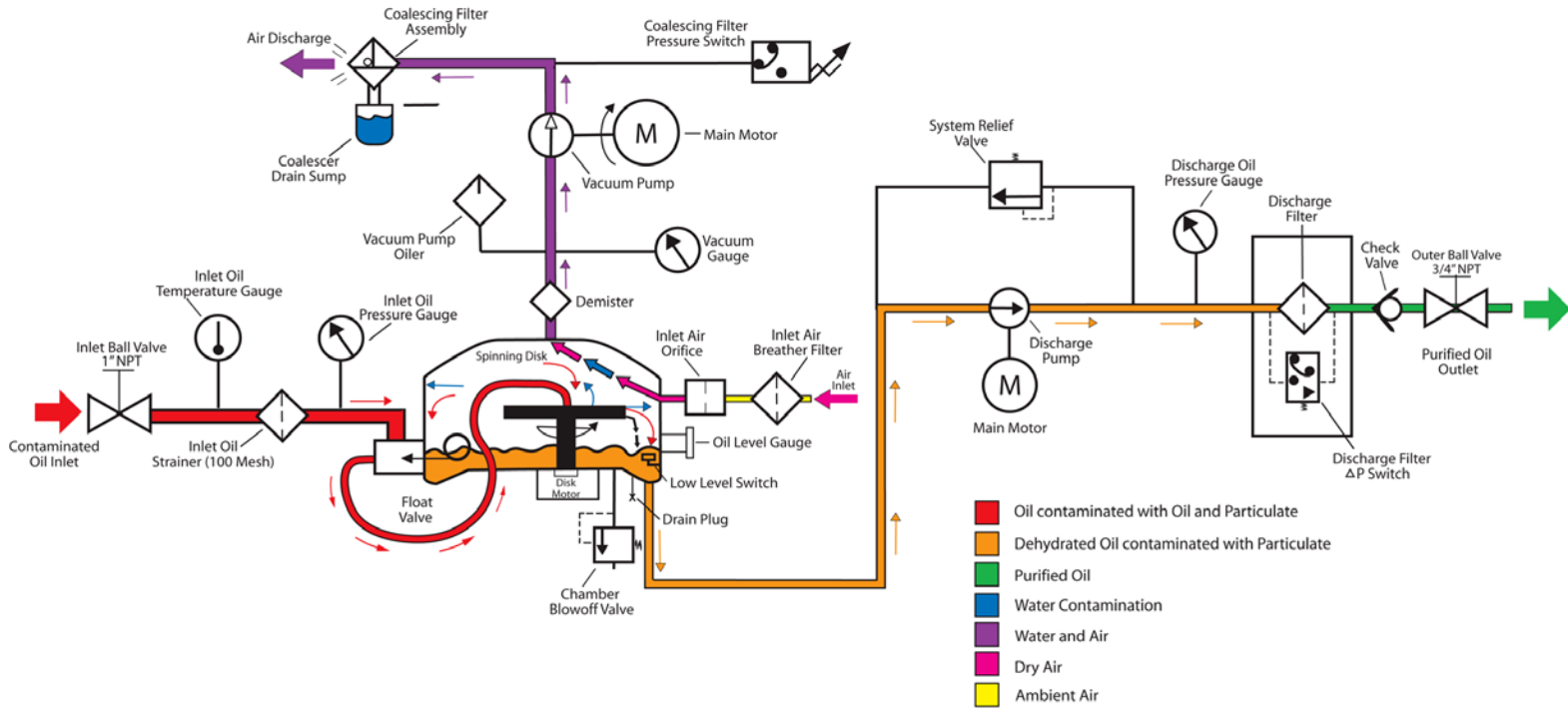

- Contaminated fluid is drawn into the spinning disk vacuum chamber through a mesh strainer. A float valve regulates the inlet flow, keeping it equal to the output of the discharge pump.
- Oil entering the vacuum chamber impinges on the center of the spinning disk. As the disk rotates, oil flows outward to the edge of the disk, progressively decreasing in film thickness. The oil is thrown off the disk and breaks into very small droplets yielding a large surface area.
- Maximizing surface area directly increases the water removal rate of fluid dehydrators. Pall's unique spinning disk technology produces a uniform surface area significantly greater than that achieved by other mass transfer devices.
- Ambient air is drawn into the vacuum chamber through an air breather filter. The air expands to approximately five times its former volume, resulting in an 80% reduction relative humidity. Water, air and solvents are carried from the vacuum chamber with the dehumidified air flow as exhaust.
- Dehydrated fluid from the vacuum chamber exits the purifier via a discharge pump through a 3 μ m absolute non-bypass discharge filter with an extremely high dirt capacity (service life).

Making a Great Product Even Better

The Pall Water Sensor Option

When you need to know water contamination levels, the Pall water sensor is the answer.



The Pall water sensor is option “W” on the Pall portable fluid purifier. This fast acting, highly repeatable in-line device measures relative humidity and temperature which are used to calculate parts per million (PPM) water content. Fluid relative humidity is the amount of dissolved water in a fluid expressed as a percentage of the amount of water necessary to cause 100% saturation. This in-line device provides instant feedback on water contamination of the fluid being purified.

Purifier Specifications

Flow:	3 gpm (11 L/min.)
Maximum Dimensions:	36" L x 27-1/2" W x 35" H (91 cm X 70 cm X 89 cm)
Electrical Requirements	120V/1PH/60HZ - units draw 15 amps maximum current. <i>Many other electrical configurations are available. Refer to table on page 7.</i>
Maximum Weight:	410 lbs. (186 kg) dry weight
Operating Vacuum:	24" Hg (610 mm Hg)
Maximum Viscosity:	1300 SSU (260 cSt)
Inlet Port:	1" NPT
Outlet Port:	3/4" NPT

WARNING: Adequate venting precautions must be taken when purifying oil contaminated with toxic fluid. A pneumatic version of the Purifier must be used for oils contaminated with flammable fluids with a flash point below 180° F (82° C).

Features

The PAC portable fluid purifier is easy to connect, simple to operate and requires minimum operator attention. It uses standard line voltage and is easily connected to your system using inlet and outlet hoses. There are no adjustments to make, no controls to set; unit is self-contained.

System Reliability

Proven system with more than 3,000,000 operating hours logged.

Easily Portable

Small, lightweight, and mounted on wheels for high mobility.

Service Indicators

Indicator lights signal the condition of the filters when element change is required.

Unattended Operation

Automatic controls will safely shut down the unit if fluid levels and pressures venture outside normal limits.

High Efficiency Particulate Removal Filter

Solid particulate removal is achieved using a highly efficient 3 µm absolute filter with a minimum 99.5% gravimetric efficiency when tested per MIL-PRF-81836, and $\beta_{3 [5(6)]} \geq 2000$, when tested per ISO 16689.

Unique Operating Principle

Removes free and dissolved water, as well as free, entrained, and dissolved gases, and particulate contamination.

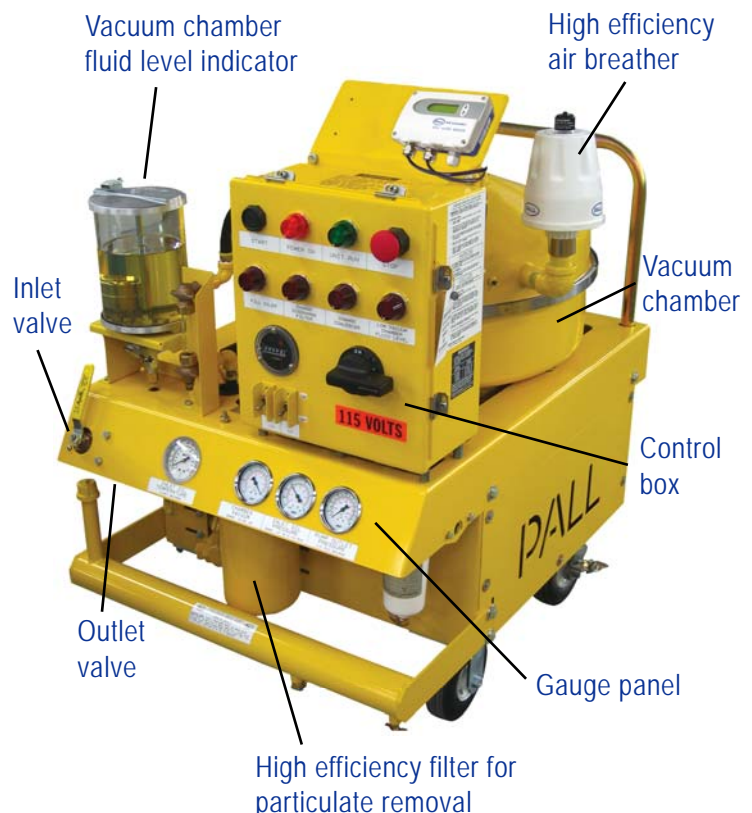

PE01078 -GG -G -G -GG

TABLE 1	
CODE	VOLTAGE / FREQUENCY
12	120 V/60 HZ
20	208 V/60 HZ
23	230 V/60 HZ
46	460 V/60 HZ
57	575 V/60 HZ
11	110 V/50 HZ
22	220 V/50 HZ
38	380 V/50 HZ
44	440 V/50 HZ

See Table 1

See Table 2

See Table 3

See Table 4

TABLE 2	
CODE	SEAL OPTION
H	Buna-N
Z	Viton
J	EPR

TABLE 3	
CODE	SPECIAL OPTIONS / ACCESSORIES
OMIT	Not Specified
W	Water Sensor

TABLE 4			
CODE	TEST FLUID	CODE	TEST FLUID
OMIT	Not Specified	50	* SKYDROL 500
10	Mineral Oil - Drakeol 10B	51	* SKYDROL LD-4
11	MOBIL-DTE 11	52	** HYJET IV
13	MOBIL-DTE 13	56	MIL-PRF-5606
15	Omala 150	57	MIL-PRF-87257
16	MIL-DTL-1711	60	UNIVOLT 60
17	MIL-PRF-1733	68	MIL-PRF-6083
18	FYRQUEL EHC	70	MIL-PRF-7024
19	MIL-H-19457	72	MIL-PRF-17672
23	MIL-PRF-23699	78	MIL-PRF-7808
24	MOBIL-DTE 24	80	TURBO OIL 2380
25	MOBIL-DTE 25	83	MIL-PRF-83282
40	FC-40 (3M Fluorinert)	87	MIL-PRF-87252 (PAO)
46	MIL-PRF-46170	90	2190-TEP
47	* COOLANOL 20	91	Dextron III Trans. Fluid
48	* COOLANOL 25		

SEAL OPTION FOR TABLE 2			
BUNA N (NITRILE)		VITON	EPR
TABLE 2 = H		TABLE 2 = Z	TABLE 2 = J
MIL-PRF-87252	MIL-PRF-87257	MIL-PRF-7808	MIL-H-19457
MIL-PRF-5606	MIL-DTL-17111	MIL-PRF-23699	Type IV & V Phosphate Esters
MIL-PRF-6083	MIL-PRF-17331	Turbo Oil 2380	Hyjet ** IV
MIL-PRF-46170	MIL-PRF-17672	Specific Synthetics	Skydrol * LD-4
MIL-PRF-83282	2190-TEP		Skydrol * 5008-4
	PAO Coolants		Organic Esters
Petroleum Base	Numerous Others	Numerous Others	Numerous Others



WHY REUTILIZE OIL?

Environmental and Cost Savings

- ✦ less new fluid purchased and reduced disposal costs

Enhanced Readiness

- ✦ improved system performance

Durability

- ✦ reduced system maintenance, extended service life of oil and components

Pollution Prevention

Fluid Recycling



Waste Stream Minimization

Fluid Service Life Extension



Pall Corporation

PALL AEROPOWER CORPORATION

10540 Ridge Road
New Port Richey, FL 34654

727.849.9999 phone
727.839.7313 fax

Visit us on the Web at www.pall.com

Pall Corporation has offices and plants throughout the world.